

Working in Power

UTM-1080 series

online UPS

10-20 kVA single/single-phase and three/single-phase
10-80 kVA three-phase/three-phase

- LOCAL AREA NETWORKS (LAN)
- SERVERS
- DATA CENTERS
- INTERNET CENTERS (ISP/ASP/POP)
- INDUSTRIAL PLCS
- EMERGENCY DEVICES (LIGHTS/ALARM)
- ELECTRO-MEDICAL DEVICES
- TELECOMMUNICATIONS DEVICES
- INDUSTRIAL APPLICATIONS

UTM-1080 series

The **UTM-1080** series includes 10-15-20kVA single/single-phase, three/single-phase and 10-15-20-30-40-60-80kVA three phase models, and uses double conversion on-line technology(VFI).

The load is powered continuously by the inverter with a filtered, stabilised and regulated sinewave supply. The input and output filters considerably increase the immunity of the load to mains disturbances and surges, even on bypass.

For technology, outstanding performance(selectable operating modes: On-line, Economy, Smart-Active, Standby/Off – for emergency lightning applications) and automatic voltage stabiliser, advanced diagnostics (standard LCD display with 128 readings, RS232 interfaces with **PowerShield²** software included, EPO input contact, and a network interface slot), **UTM-1080** provides maximum protection for vital 'mission-critical' networks and security application (electromedical).

Additional battery extension packs allow the standard battery runtime to be extended up to several hours.

Note the simple installation: the UPS can be connected both to single-phase and three-phase mains supplies.

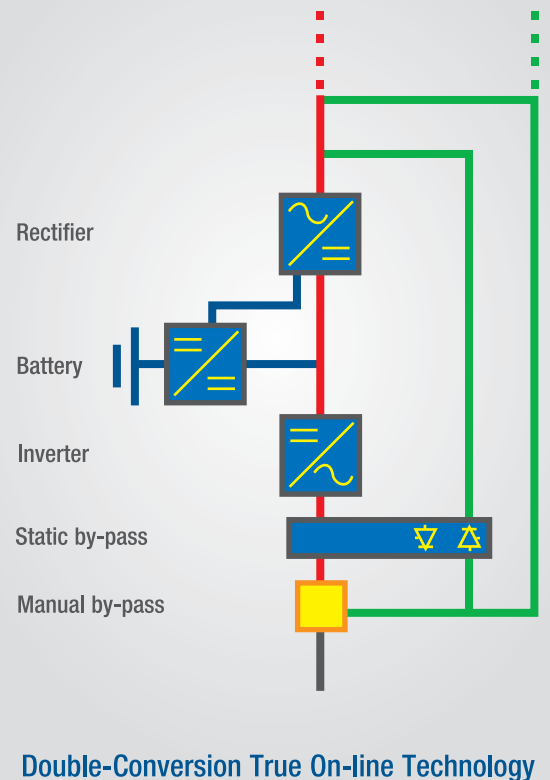

Double-Conversion True On-line Technology

Main Features:

- Reliable, filtered, stabilised and regulated sinewave output (double on-line conversion technology VFI according to EN50091-3 specifications) with filters for atmospheric disturbance suppression
- High reliability: IGBT technology, full microprocessor control with no-break static and manual bypass
- High level diagnostics: event log with 128 messages, states, measurements and alarms - available from the built-in LCD in several languages
- Reduced noise levels: high frequency inverter bridge used (>16 kHz: above audible range)
- Simple to install:
 - capability to connect the UPS both to single-phase and three-phase mains supplies
 - panel to offset voltage drop down long cable runs
- Maximum reliability and power availability - connect up to 8 units in parallel or N+1 redundancy, even of different power ratings (optional)
- High level battery reliability:
 - automatic battery test
 - recharge compensated for temperature
- Low loss high efficiency up to 92% in On-line mode utilizing IGBT technology and up to 98% in the other operating modes: "Economy Mode", Smart Active Mode, and Standby Off Mode
 - Economy Mode: uses Line Interactive (VI) technology to power less critical loads from the mains supply for certain periods. The function can be set from the front panel keypad or remotely using software
- Low harmonic pollution in the Aries Clean version the electronic digital (DSP control) active filter allows: (Optional)
 - very low distortion (THDi<5%) - compact cabinet (internal option)
 - high efficiency: the active filter does not reduce operational efficiency
- Emergency operation: the UPS can be set to operate only when the mains fails (for emergency lighting)
- Back feed protection: to avoid energy feeding back into the mains supply
- By pass may be deactivated to allow operation as frequency converter (at 50 or 60 Hz)

Simplified Maintenance

Access for maintenance is entirely from the front of the unit. Open the door and remove the protective panel (standards requirement) and the power components - mounted on a sliding tray - can be pulled out to provide easy access to all the electrical and electronic components for maintenance and repair work.

This particular feature means that the MTTR (Mean Time To Repair) is less than 30 minutes.

A large amount of maintenance information is available from the front mimic panel and LCD.

In addition system operating parameters are software configurable via a local PC to allow new functions to be added or adjustments made to operating specifications.



UPS Front Panel

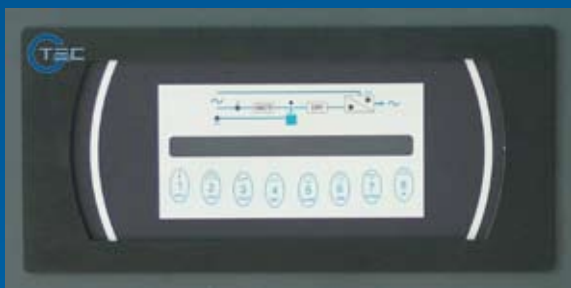

1. Language selection
2. Input/output measurements
3. Controls/settings/customisations
4. Event log
5. Buzzer reset
6. Time/date
7. Scroll back
8. Scroll forward

Buttons 7 and 8 are used to display detailed system control information

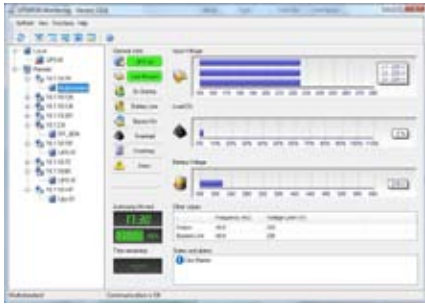

DETAILED UPS PARAMETER DISPLAY

PowerShield² provides all the information required for first level diagnostics



BLOCK AND FUNCTIONAL DIAGRAMS

PowerShield² also displays the UPS in block format providing the user with information regarding operating status

Direct Connection with Ethernet Network

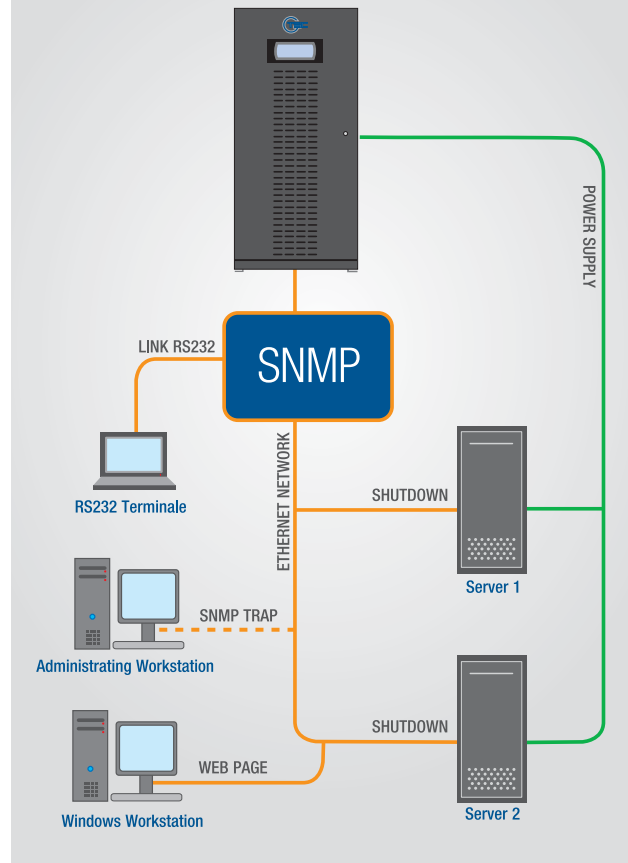

Communication Solutions

ADVANCED COMMUNICATION

- Compatible with TELEGUARD for remote maintenance
- Advanced, multi-platform communication, for all operating systems and network environments: PowerShield² supervision and shut-down software included, with SNMP agent, for Windows 95, 98, 2000, Me, XP, Mac OSx, 9.x, Linux, NT 4.0, Novell operating system. The UPS is equipped with a cable for direct connection to the PC (plug and Play)
- Can also provide shut-down software for: IBM AIX; Free BSD; BSDI UNIX; BSD/OS; Unixware; SCO Openserver; Solaris; SUN; DEC; Compaq True64; HP UNIX; SGI Irix MIPS; NCR UNIX
- Double RS232 serial port
- Network adapter slot for SNMP agent
- EPO (Emergency Power Off) shut down input contact
- Remote control panel (optional)

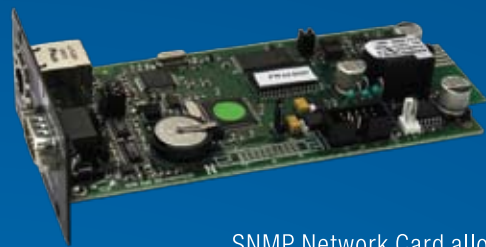

SNMP Network Card allows management of UPS across LAN using any of the main network communication protocols - TCP/IP and network interface via SNMP

*All the trademarks indicated are the property of their respective owners.

TECHNICAL **ASSISTANCE** SERVICE

UPService, our technical assistance facility uses highly trained engineers to provide a reliable and competent technical support and after-sales service.

UPService can provide customers with:

- A dedicated CALL CENTRE for connection to the UPService organisation. UPService personnel are always available and ready to provide advice and assistance regarding UPS installation, maintenance, fault finding and repair.
- **FAST & READY** A fast repair on site is guaranteed through the use of state-of-the-art UPS technology and the professionalism of the UPService personnel and Authorised Assistance Centres. UPService guarantees that failed parts are replaced with original ones, tested and updated in order to maintain the safety, reliability and operating characteristics of the UPS.
- **COMMISSIONING AND START-UP** UPService can provide assistance during commissioning and startup of the UPS equipment on-site with additional training during handover to site personnel. UPService engineers can also verify site suitability, analyse and advise on potential problems, and disconnect and relocate equipment. UPService recommend that all hardwired installations are commissioned by UPService engineers.
- **MAINTENANCE CONTRACTS** can be provided by UPService to minimise response times and repair costs. Contracts range from periodic inspections to comprehensive cover including labour and materials.
- The **TELEGUARD** software package provides remote 24x7 UPS supervision. TeleGuard can interrogate G-TEC UPS connected to a local telephone line to check on their operating logs and system status. Should the UPS report an alarm condition, the UPService Call Centre is immediately notified and a dedicated customer response activated. Routine site reports can be sent automatically to customer personnel.
- UPService organises regular **TECHNICAL TRAINING COURSES** for UPS operators and installers.



TECHNICAL **ASSISTANCE** SERVICE

UTM-1080 series

TECHNICAL SPECIFICATION			
Three/Single phase Model	10M	15M	20M
INPUT			
Rated voltage	230 Vac single-phase or 400 Vac three-phase + N		
Voltage range	+20%, -30%		
Frequency range	45Hz ~ 65Hz		
Power Factor	≥ 0.99		
Current distortion	Sinusoidal absorbing (CLEAN Version)		
BYPASS			
Rated voltage	230 Vac		
Number of phases	single-phase		
Permitted voltage range	± 15% (selectable from ± 5% to ± 25%)		
Rated frequency	50Hz / 60Hz		
Permitted frequency range	± 2% (selectable from ± 1% to ± 5%)		
BATTERIES			
Type	Maintenance-free sealed lead-acid		
Recharge time	6h		
OUTPUT			
Rated power (kVA)	10	15	20
Active power (kVA)	8	12/10.5 (1Ø input)	16/12 (1Ø input)
Number of phases	1		
Rated voltage (V)	220/230/240 selectable		
Voltage requalification range	200 - 250 Vac		
Crest Factor (I _{peak} /I _{rms})	3:1		
Waveform	Sinewave		
Distortion with linear load	1%		
Static stability	± 1%		
Dynamic stability	± 5% in 5ms		
Frequency	50/60 Hz selectable		
Overload	125% 150% 200% of the rated current for 10'/1'7"		
ENVIRONMENTAL			
Remote signaling	volt free contacts		
Remote controls	EPO and bypass		
Communication	Double RS232/C - network adapter slot for SNMP agent		
Operating temperature	0 - 40°C		
Relative humidity	95% (non condensing)		
Colour	Dark Grey RAL 7016		
Noise	< 55 dBA at 1m		
Protection rating	IP20		
Efficiency	> 98% in Economy Mode/Smart Active Mode/Standby Off Mode/AVR Mode		
Compliance	Safty En 50091-1-1 EMC EN 50091-2 Directives 73/23-93/68-89/336 EEC		
Weight (kg)	from 90 to 218	from 95 to 285	from 110 to 300
Dimension (mm) (LxDxH)	500x740x1400		

Option:

CLEAN VERSION for 5% THDi, Remote Monitor Panel, Communication Software & Accessories, Isolation transformer, Parallelable 8 units.

Note:

UPS specification and data may subject to change for improvement without prior notice.
 UPS three-phase/single phase series: The input cables and protection must be capable of supplying the fully rated single phase output load should UPS switches to bypass mode.

UTM-1080 series

TECHNICAL SPECIFICATION							
Three/Three Phase Model	10T	15T	20T	30T	40T	60T	80T
INPUT							
Rated voltage	400 Vac three-phase + N						
Voltage range	+20%, -30%						
Frequency range	45Hz ~ 65Hz			45Hz ~ 65Hz			
Power Factor	≥ 0.95						
Current distortion	Sinusoidal absorbing (CLEAN Version)						
BYPASS							
Rated voltage	400 Vac						
Number of phases	3Ø + N						
Permitted voltage range	± 15% (selectable from ± 5% to ± 25%)						
Rated frequency	50Hz / 60Hz (Auto Sensing)						
Permitted frequency range	± 2% (selectable from ± 1% to ± 5%)						
BATTERIES							
Type	Maintenance-free sealed lead-acid						
Recharge time	6h			4-8h			
OUTPUT							
Rated power (kVA)	10	15	20	30	40	60	80
Active power (kVA)	8	12	16	24	32	48	64
Number of phases	3Ø + N						
Rated voltage (V)	380/400/415 selectable						
Voltage regulation range	346 - 433 Vac						
Crest Factor (I _{peak} /I _{rms})	3:1						
Output Current	15A	22A	29A	43.5A	58A	87A	116A
Distortion with linear load	1%						
Static stability	± 1%						
Dynamic stability	± 5% in 10ms						
Frequency	50Hz / 60Hz (Auto Sensing)						
Overload	125% 150% 200% of the rated current for 10'/1'/7"						
ENVIRONMENTAL							
Remote signaling	volt free contacts						
Remote controls	EPO and bypass						
Communication	Double RS232/C - network adapter slot for SNMP agent						
Operating temperature	0 - 40°C						
Relative humidity	95% (non condensing)						
Colour	Dark Grey RAL 7016						
Noise	< 53 dBA at 1m			< 56 dBA at 1m			
Protection rating	IP20						
Efficiency	> 98% in Economy Mode/Smart Active Mode/Standby Off Mode/AVR Mode						
Compliance	Safty EN 50091-1 EMC EN 50091-2 Directives 73/23-93/68-89/336 EEC						
Weight (kg)	from 90 to 223	from 100 to 290	from 115 to 305	from 120 to 310	180	200	220
Dimension (mm) (LxDxH)	500x740x1400						

Option:

CLEAN VERSION for 4%-5% THDi, Remote Monitor Panel, Communication Software & Accessories, Isolation transformer, Parallelable 8 units.

Note:

UPS specification and data may subject to change for improvement without prior notice.